



X-Sential™

Technical data sheet

NIR-Online®

All NIR-Online sensors are based on diode-array technology. The compact, robust instrument is equipped with a flange and sapphire window. It can be directly mounted to a process vessel or tube. Additional accessories for solid and liquid products are available.

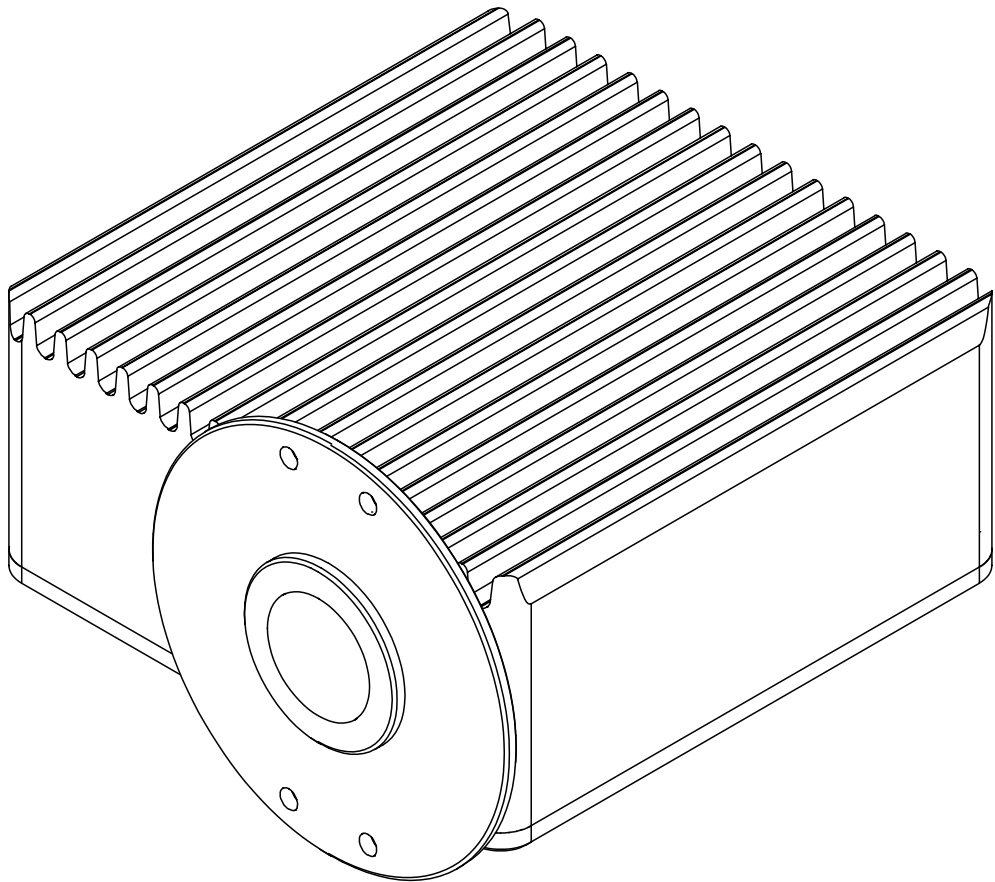

Алматы (7273)495-231
Ангарск (3955)60-70-56
Архангельск (8182)63-90-72
Астрахань (8512)99-46-04
Барнаул (3852)73-04-60
Белгород (4722)40-23-64
Благовещенск (4162)22-76-07
Брянск (4832)59-03-52
Владивосток (423)249-28-31
Владикавказ (8672)28-90-48
Владимир (4922)49-43-18
Волгоград (844)278-03-48
Вологда (8172)26-41-59
Воронеж (473)204-51-73
Екатеринбург (343)384-55-89

Иваново (4932)77-34-06
Ижевск (3412)26-03-58
Иркутск (395)279-98-46
Казань (843)206-01-48
Калининград (4012)72-03-81
Калуга (4842)92-23-67
Кемерово (3842)65-04-62
Киров (8332)68-02-04
Коломна (4966)23-41-49
Кострома (4942)77-07-48
Краснодар (861)203-40-90
Красноярск (391)204-63-61
Курск (4712)77-13-04
Курган (3522)50-90-47
Липецк (4742)52-20-81

Магнитогорск (3519)55-03-13
Москва (495)268-04-70
Мурманск (8152)59-64-93
Набережные Челны (8552)20-53-41
Нижний Новгород (831)429-08-12
Новокузнецк (3843)20-46-81
Ноябрьск (3496)41-32-12
Новосибирск (383)227-86-73
Омск (3812)21-46-40
Орел (4862)44-53-42
Оренбург (3532)37-68-04
Пенза (8412)22-31-16
Петрозаводск (8142)55-98-37
Псков (8112)59-10-37
Пермь (342)205-81-47

Ростов-на-Дону (863)308-18-15
Рязань (4912)46-61-64
Самара (846)206-03-16
Санкт-Петербург (812)309-46-40
Саратов (845)249-38-78
Севастополь (8692)22-31-93
Саранск (8342)22-96-24
Симферополь (3652)67-13-56
Смоленск (4812)29-41-54
Сочи (862)225-72-31
Ставрополь (8652)20-65-13
Сургут (3462)77-98-35
Сыктывкар (8212)25-95-17
Тамбов (4752)50-40-97
Тверь (4822)63-31-35

Тольятти (8482)63-91-07
Томск (3822)98-41-53
Тула (4872)33-79-87
Тюмень (3452)66-21-18
Ульяновск (8422)24-23-59
Улан-Удэ (3012)59-97-51
Уфа (347)229-48-12
Хабаровск (4212)92-98-04
Чебоксары (8352)28-53-07
Челябинск (351)202-03-61
Череповец (8202)49-02-64
Чита (3022)38-34-83
Якутск (4112)23-90-97
Ярославль (4852)69-52-93

Россия +7(495)268-04-70

Казахстан +7(7172)727-132

Киргизия +996(312)96-26-47

<https://buchi.nt-rt.ru/> || bic@nt-rt.ru

Sensor portfolio

Different detectors can be combined in one instrument to meet a wide variety of requirements.

Available instrument configuration	NIR	VIS Imaging	Dual lamp	Measuring distance	extended wavelength range (PA2)	Dust-Ex	Gas-Ex	high speed version (V3S)
X-Sential 11XS-Series	•	•	•	0 - 20 mm				
X-One 11X1-Series	•		•	0 - 20 mm	•	•	•	•
X-Two 11X2-Series	•		•	0 - 20 mm	•	•		
X-Three 11X3-Series	•	•	•	0 - 20 mm	•	•	•	
X-Four 11X4-Series	•	•	•	0 - 20 mm	•	•		
X-Beam 002 11XB2-Series	•	•	•	100 - 200 mm		•	•	
X-FFPA 11XF-Series	•	•		immersion		•		
Multipoint System	•		•	0 - 20 mm		•		

Standard instrument front and rear view

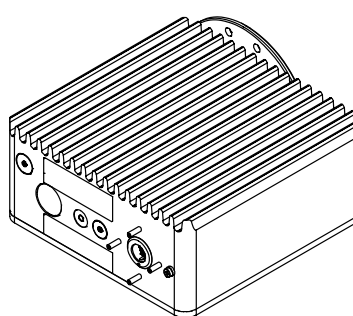
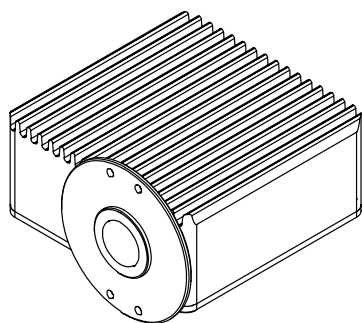

Technical data

Sensor

Specifications	X-Sential
Dimensions (W x D x H)	200 x 200 x 100 mm
Weight	5 kg
Max. operating pressure	30 bar at flange
Product temperature (temperature at flange with water cooling)	-10 °C to +130 °C
Product temperature (temperature at flange with- out water cooling)	-10 °C to + 70 °C
Vibrations	0.2 G at 0.1 - 150 Hz
Wavelength spectrum NIR range	900 - 1700 nm; 11100 - 5880 cm ⁻¹
Wavelength spectrum Visible range	350 - 900 nm; 28500 - 11100 cm ⁻¹
Detector	Diode array
Average measurement time	20 spectra/s
IP Code	IP69 / IPX9K
Type of lamp	Tungsten-halogen dual lamp
Lifetime lamp	18000 h (2 x 9000 h)
Minimum clearance on all sides	100 mm
Connection Voltage	85 to 264 VAC
Frequency	50/60 Hz
Power consumption	30 W
Temperature stabilization	ASDC (Advanced Spectral Drift Control): active temperature control to ±1°C from set system operating temperature. Deviations will lead to automatic white reference measurement to account for spectral drifts.

Materials

Component	Materials of construction
Casing	Aluminium (nickel coated), SS 316L 1.4404 flange
Seals	NBR (standard sealing material) FFKM (optional)

Ambient conditions

Max. altitude above sea level	No restrictions
Ambient temperature	$-10\text{ °C} \leq T_{\text{amb}} \leq +40\text{ °C}$
Max. relative air humidity	< 90 % non-condensing
Storage temperature	max. 45 °C

Computer system requirements

The system requirements for the computer are as follows:

Operating system	Windows 10 Pro
Central processing unit	Intel Core i5 generation 6600 or later
RAM	At least 4 GB
Hard disk space	At least 80 GB free disk space Use a hard disk suitable for continuous operation.
Data backup	At least 0.5 GB free disk space
Network or external hard disk	Additional 20 MB per day and sensor
Screen resolution	At least 1280x1024
LAN	At least 1 x 100 Mbit/s LAN
USB 2.0/3.0	At least 1 USB connection per sensor and 1x USB per DataLab I/O box
PCI/PCIe	1 slot for Profibus card (for Profibus connection)
Software	Word and Microsoft Excel 2003 or later

Software

The sensor is controlled via the SX-Suite software package. It consists of the following components:

Name	Description	Typical usage	User	Occurrence
SX-Server	Instrument driver / usage of special functions	Read out instrument status	Operator	As required
		Setup of instrument hardware	NIR admin	For installation and maintenance

Name	Special function	Description	User	Occurrence
SX-Server	Conveyor belt	Optimized for measurement of moving objects on a conveyor belt	NIR admin	As required
	Mix	Control end-point of mixing processes	NIR admin	As required
	Sample movement detection	Verify sample flow	NIR admin	As required

Name	Description	Typical usage	User	Occurrence
SX-Center	User interface (online/lab mode)	Recipe/product and calibration management	Operator	Daily workflow (if not fully automated)
		View results (table, trend, charts, reports)		
		Reference data management		
SX-Backup	Data backup scheduler	Automated backup of measurement data, results and calibrations	NIR admin	During installation

Optional software

Software	Description	Typical usage	User	Occurrence
AutoCal®	Automated calibration feature	If new reference data is available the calibration is updated and optimized automatically	Operator (to enter reference data)	When calibration update is needed
SX-Plus	Chemometric software	Manual build up or optimization of existing calibrations	NIR-admin	When calibration update is needed
SX-Client	Remote data visualizing	Display the front page of SX-Center from a remote PC	Operator, NIR-admin	Daily use (if not fully automated)

Interfaces process analyzer to computer

Interface	Hardware	Details
RS422	USB adapter	<ul style="list-style-type: none"> • Converts the instruments RS422 signal via USB to a serial COM-port • 15 KV ESD protection
	LAN adapter	<ul style="list-style-type: none"> • Converts the instruments RS422 signal via ethernet to a virtual COM-port • 15 KV ESD protection

Interfaces to process control system

Interface	Hardware	Details
Analog	Datalab I/O	<ul style="list-style-type: none"> • Analog output of results • Alarm output • Heartbeat toggle for verification of interface • Total outputs: 8 max. 4 parameters via 4 - 20 mA max. 8 parameters via 1 - 9 V
Profibus	Softing PB-IF-1MS or PB-IF-1S	<ul style="list-style-type: none"> • Transmission counters to monitor function • Profibus and TCP/IP cannot be used at the same time • Additional NIR-Online Software (SX-Profi) required
TCP/IP, RS232	Standard ethernet card	<ul style="list-style-type: none"> • Transmission counters to monitor function • Profibus and TCP/IP cannot be used at the same time
OPC	Standard ethernet card	<ul style="list-style-type: none"> • Additional tool which allows communication between SX-Center and a process control system • Additional NIR-Online Software (SX-OPC) required
Modbus	Standard ethernet card	<ul style="list-style-type: none"> • Additional tool which allows communication between SX-Center and a process control system • Additional NIR-Online Software (SX-Modbus) required
SQL	Standard ethernet card	<ul style="list-style-type: none"> • Additional tool which allows data export between SX-Center and a process control system/LIMS

Accessories

Installation boxes

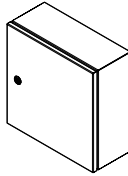
	Order no.	Image
Installation Box Standard	11060744	
Installation Box Standard EB	11063054	



Specifications	Installation box
Dimensions (W x D x H)	300 x 300 x 167 mm
Weight (excluding cables)	6 kg
Weight (inc. cables, 2 x 10 m)	7.4 kg
Frequency	50/60 Hz
Power consumption	30 W
Power supply	85 - 264 VAC

There are various types of installation boxes that are compatible with this sensor. All installation boxes can be found in the pricelist.

Mounting accessories

Mounting accessories are hardware interfaces between the instrument and the process. Depending on the setup, specific mounting accessories might be needed for an implementation into the production facility.

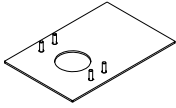
	Order no.	Image
Weld-in Flange Provides the ability to remove instrument while keeping the process sealed. Flange with sapphire window and purge port. <ul style="list-style-type: none">• Adapter plate, $\varnothing 140/106$ mm, for wall thickness up to 8,5 mm• Material: Stainless steel DIN 1.4404 (SST316L) / DIN 1.4571 (SST316Ti)• Sealing material FFKM White G74S, FDA compliant 15°C (+59°F) to 260°C (+500°F)• Operating pressure -0.5 to 30 bar. Max. pressure 100 bar short term• Purge port M5 ($\varnothing 4$mm tube adapter needed) to prevent condensation or detect leakage• High grade sapphire crystal optical lens, polished for reduced adhesion• Dead volume max. 60 mm³	11060754	
Weld-in Flange Pipe Flange with sapphire window and purge port for installation in pipes or bended surfaces. <ul style="list-style-type: none">• Outer diameter: 140 mm.• Material: Stainless steel DIN 1.4404 (SST316L)• Sealing material: FFKM White G74S• Operating pressure: -0.5 to 30bar. Max. pressure 100 bar short term• Purge port M5 ($\varnothing 4$mm tube adapter needed) to prevent condensation or detect leakage• The pipe diameter has to be specified upon order	11068800	
Weld-in Flange Hopper Flange with sapphire window and purge port for installation in hopper or bended surfaces with different diameters. <ul style="list-style-type: none">• Outer diameter: 140 mm• Material: Stainless steel DIN 1.4404 (SST316L)• Sealing material: FFKM White G74S• Operating pressure: -0.5 to 30bar. Max. pressure 100 bar short term• Purge port M5 ($\varnothing 4$mm tube adapter needed) to prevent condensation or detect leakage• The upper and lower hopper diameter has to be specified upon order	11068801	

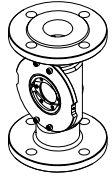
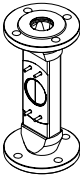
	Order no.	Image
<p>Weld-in Plate</p> <p>For instruments in direct contact with the product.</p> <p>Plate with opening, fitting to instrument flange.</p> <ul style="list-style-type: none"> • Dimensions: 160 x 241 x 3 mm • Material: DIN 1.4301 (SST304) • Thread bolts M6 	11060753	
<p>Bypass Sampler</p> <p>For free flowing goods (mealy / grainy).</p> <p>Bypass with feeder and sampling point.</p> <ul style="list-style-type: none"> • Pneumatic sampler (min. 5 bar / 72.5 psi water or oil free compressed air DIN ISO 8573 Class 1) • Screw-conveyor (feeding capacity 1.5 t/h) • Motor (380V/50Hz ATEX A22 0.25 KW) • Requires bypass-installation box and a DataLab IO device 	11061670	
<p>X-Square</p> <p>For all free flowing powders and granulates.</p> <p>The X-Square can be inserted in the product stream or bypass.</p> <ul style="list-style-type: none"> • Inspection panel (Plexiglas) • Adapted for Jacob pipes Ø150 mm • Stainless steel DIN 1.4301 electro polished 	11061669	
<p>X-Cell DN50, Standard Flange DN50, PL1, 10 bar</p> <p>For gas, liquid and paste-like products.</p> <p>The cell can be inserted in the product stream or bypass.</p> <ul style="list-style-type: none"> • Material DIN 1.4404 (SST316L) • Sealing material: FFKM White G74S • Operating pressure up to 10 bar (145 psi). TÜV certificate upon request • Measurement slit 26 mm, configurable between 1 and 15 mm with additional adapter • DN 50 flange (other sizes upon request) • Clearance volume max. 120 mm³ Cells can be customized with different diameter and flanges <p>There are various dimensions of the X-Cell available in the pricelist.</p>	11063018	
<p>X-Cell 4 Edge DN50</p> <p>For liquid and paste-like products.</p> <p>The cell can be inserted in the product stream or bypass.</p> <ul style="list-style-type: none"> • Material: DIN 1.4404 (SST316L) • Sealing material: FFKM White G74S • Operating pressure: max 3bar • Flange: DN50 • Path length: 34mm • Typical use: Wine Applications 	11068822	

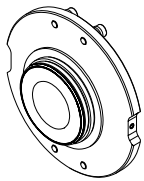
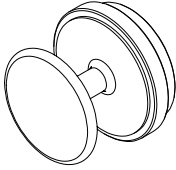
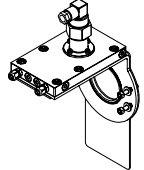
	Order no.	Image
VARINLINE Sensor Adapter Flange, Type N, 10bar For opaque products like powder or granules. In combination with a path length adapter also for transparent liquid, gel or pasty products. <ul style="list-style-type: none"> • Material DIN 1.4404 (SST316L) • Sealing material FFKM White G74S (FDA compliant), or custom • Operating pressure up to 10 bar (145 psi). TÜV certificate upon request • Build for DN50 DIN 32676, process connection type N • Product temp. -14 °C(+5 °F) to 230 °C (+446 °F) • Path length adapter configurable between 0,5 to 42 mm 	11061674	
Path Length Adapter To measure transparent liquids with the X-Cell. The reflector reduces the length of the optical path. <ul style="list-style-type: none"> • Material DIN 1.4404 (SST316L) • Gap 1 / 2 / 5 / 10 / 15 mm available • Diffuse or polished surface 		
Water Cooler Flange <ul style="list-style-type: none"> • Can be used with all instruments, only in combination with X-Cell or Weld-in Flange • Product temperature above 70 °C to 130 °C. A flow rate of 5 l water per hour at 20 °C is required • 40 °C over temp switch for external alarm purpose, NO (Normally Open) circuit • Water connectors for 8/6 mm hose 	11060752	

Алматы (7273)495-231
Ангарск (3955)60-70-56
Архангельск (8182)63-90-72
Астрахань (8512)99-46-04
Барнаул (3852)73-04-60
Белгород (4722)40-23-64
Благовещенск (4162)22-76-07
Брянск (4832)59-03-52
Владивосток (423)249-28-31
Владикавказ (8672)28-90-48
Владимир (4922)49-43-18
Волгоград (844)278-03-48
Вологда (8172)26-41-59
Воронеж (473)204-51-73
Екатеринбург (343)384-55-89

Иваново (4932)77-34-06
Ижевск (3412)26-03-58
Иркутск (395)279-98-46
Казань (843)206-01-48
Калининград (4012)72-03-81
Калуга (4842)92-23-67
Кемерово (3842)65-04-62
Киров (8332)68-02-04
Коломна (4966)23-41-49
Кострома (4942)77-07-48
Краснодар (861)203-40-90
Красноярск (391)204-63-61
Курск (4712)77-13-04
Курган (3522)50-90-47
Липецк (4742)52-20-81

Магнитогорск (3519)55-03-13
Москва (495)268-04-70
Мурманск (8152)59-64-93
Набережные Челны (8552)20-53-41
Нижний Новгород (831)429-08-12
Новокузнецк (3843)20-46-81
Ноябрьск (3496)41-32-12
Новосибирск (383)227-86-73
Омск (3812)21-46-40
Орел (4862)44-53-42
Оренбург (3532)37-68-04
Пенза (8412)22-31-16
Петрозаводск (8142)55-98-37
Псков (8112)59-10-37
Пермь (342)205-81-47

Ростов-на-Дону (863)308-18-15
Рязань (4912)46-61-64
Самара (846)206-03-16
Санкт-Петербург (812)309-46-40
Саратов (845)249-38-78
Севастополь (8692)22-31-93
Саранск (8342)22-96-24
Симферополь (3652)67-13-56
Смоленск (4812)29-41-54
Сочи (862)225-72-31
Ставрополь (8652)20-65-13
Сургут (3462)77-98-35
Сыктывкар (8212)25-95-17
Тамбов (4752)50-40-97
Тверь (4822)63-31-35

Тольятти (8482)63-91-07
Томск (3822)98-41-53
Тула (4872)33-79-87
Тюмень (3452)66-21-18
Ульяновск (8422)24-23-59
Улан-Удэ (3012)59-97-51
Уфа (347)229-48-12
Хабаровск (4212)92-98-04
Чебоксары (8352)28-53-07
Челябинск (351)202-03-61
Череповец (8202)49-02-64
Чита (3022)38-34-83
Якутск (4112)23-90-97
Ярославль (4852)69-52-93

Россия +7(495)268-04-70

Казахстан +7(7172)727-132

Киргизия +996(312)96-26-47

<https://buchi.nt-rt.ru/> || bic@nt-rt.ru